

Voltage	V ±10%	380	220
Output Power	kW	2.20	2.20
Current	A	5.6	9.7
Frequency	Hz	200	200
rpm	rpm	12000	12000
Torque	Nm	1.75	1.75
Front Bearing		steel	
Vost. Bearing		radiale	
Efficiency	η	0.75	
Power factor	cos#	0.77	
Poles		2	
Service type		S1	
Insulation classoltage		F	
Cooling		Aria forzata	
Weight	kg		
Type of Protection	IP	54	

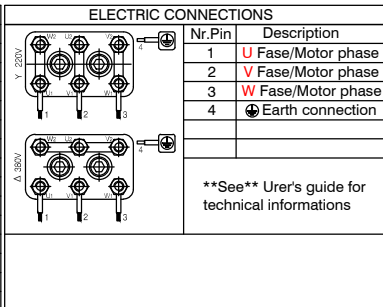

SFM4147C-12/2.20TMP



Mark	Change Description	Date:	Name
Design: M.Z.HUANG	Date: 13/07/2012	Scale:	
Check: J.F.WU	Date: 13/07/2012	Size: A4	
Approv:	Date:	Page: 1/1	

Drawing Ver : A4  
Dimensions in mm  
高速电主轴  
1120-89023

SFM4147C-ER25-380/220V-DX-12/200HZ-2.20KW/S1